



Vibration Isolation Products

Flanged Bobbin Mountings



The Flanged Bobbin Mount or DB(L)R range is composed of a rubber block bonded to an upper threaded plate and a lower metal flange. The flanged bobbin mountings are the generating set industry standard non-fail safe mountings. These bobbin mounts are easily fitted to engines, alternators, floors and chassis. Flanged Bobbin Mountings have been designed for providing low shear stiffness rates with large compression stiffness rates.

Applications Include: Generating sets, Compressors, High speed fans, Load cell protection, Bulk bin load / discharge units

LOAD / DEFLECTION CHART

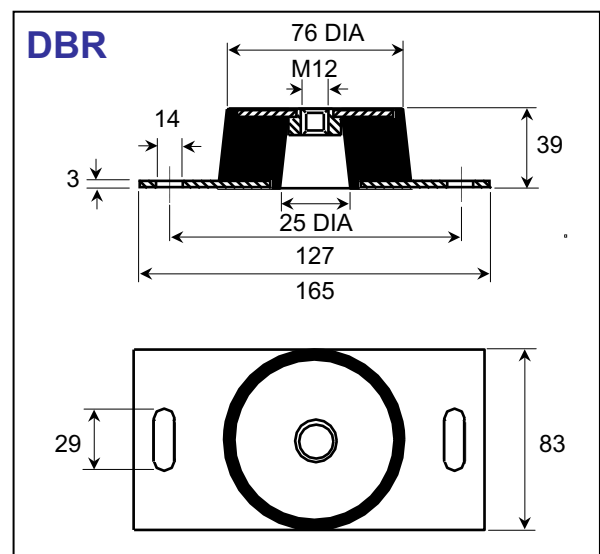
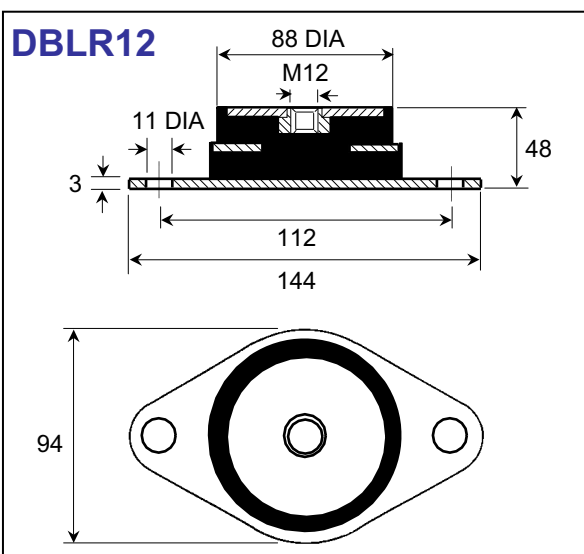
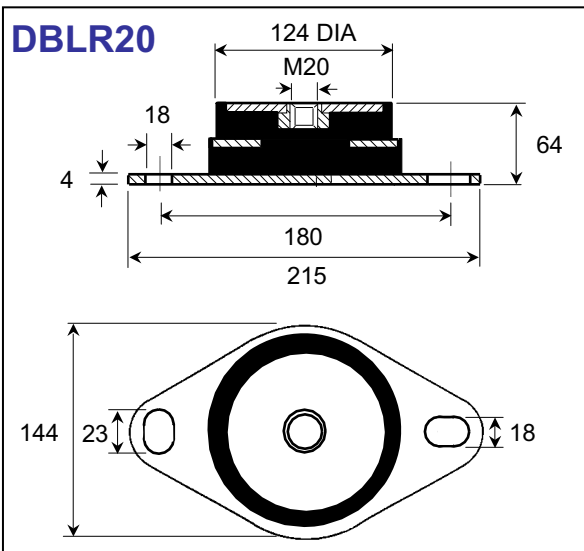
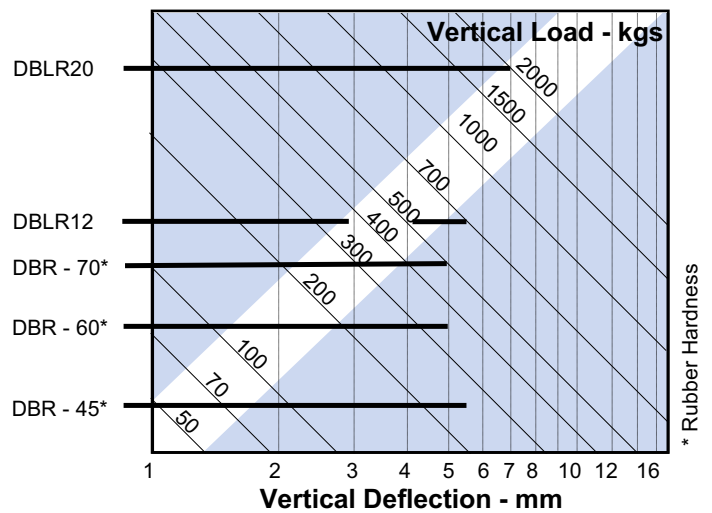

© Vibration Isolation Products Ltd 2007